

SCORPION® EXM

Efficient, high-flow, electric remote controlled water monitor (water cannon) for fire apparatus, ARFF, industrial pumper, and de-icing vehicles.

The Scorpion EXM is a large flow capacity addition to the EXM product family. Developed as the successor to the radio frequency (RF) control series, the EXM operating system is a "plug and play" digital communication and control architecture that simplifies installation while greatly expanding builder and user selectable options.

In addition to the EXM functionality, the Scorpion has been further updated to employ a new ultra high efficient waterway and axially aligned thrust bearings for a 22% increase in flow efficiency, vs. the traditional Scorpion, and 10 times greater durability.



SCORPION® EXM Monitor

Mechanical Features:

- Sealed to NEMA 6 (complete submersion)
- 2500 GPM flow
- Axially aligned thrust bearings
- Absolute position sensors
- Manual travel override
- Fully potted electronics
- Teflon impregnated, hard anodized aluminum alloy waterway
- Extreme torque motors
- High efficiency sealed planetary gearboxes

Control Features:

- Universal input voltage 11-30VDC
- Wired or wireless communication
- CAN bus J1939 compatible
- Programmable travel speeds
- Single speed, two speed, or fully proportional speed control
- Programmable 3D travel limits
- Programmable block out zones
- Programmable stow
- Programmable oscillation
- Integration water valve control
- Position display

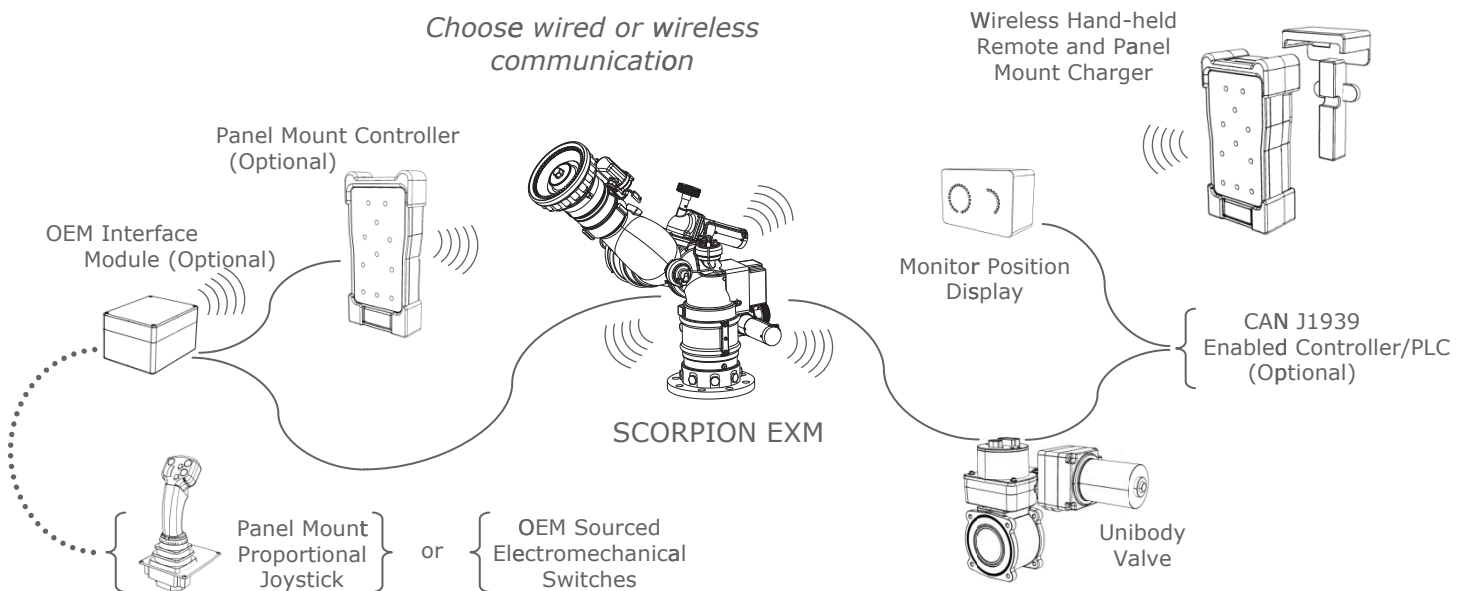

SCORPION® EXM Monitor

SPECIFICATIONS	
Model	7400
Inlet	4" ANSI / DN100
Outlet	3.5" NHT, 3.5" BSPP
Travel	V -80° to +120° H L175° to R175°
Voltage	11-27 VDC
Control	Sealed electric motors
Control Communication	CAN bus (J1939) 2.4 GHz digital radio frequency (unlicensed)
Weight	52 lbs.
Max Pressure	500 psi

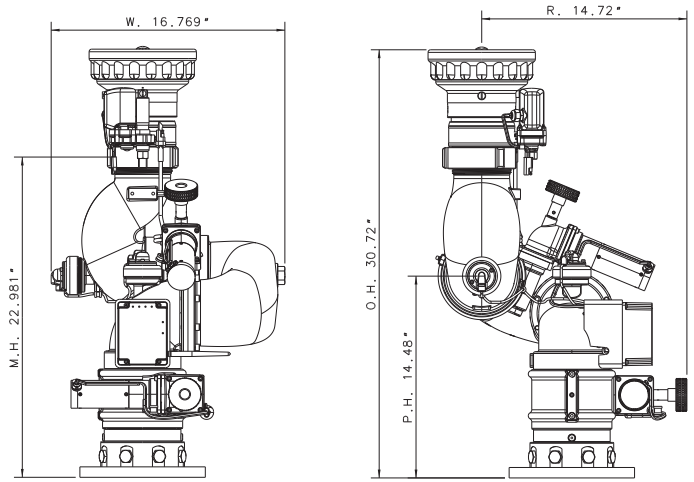

7400 Scorpion EXM Static Pressure Drop (4.0" Inlet and 3.5" Outlet)

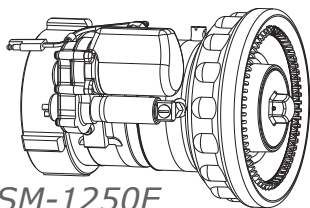
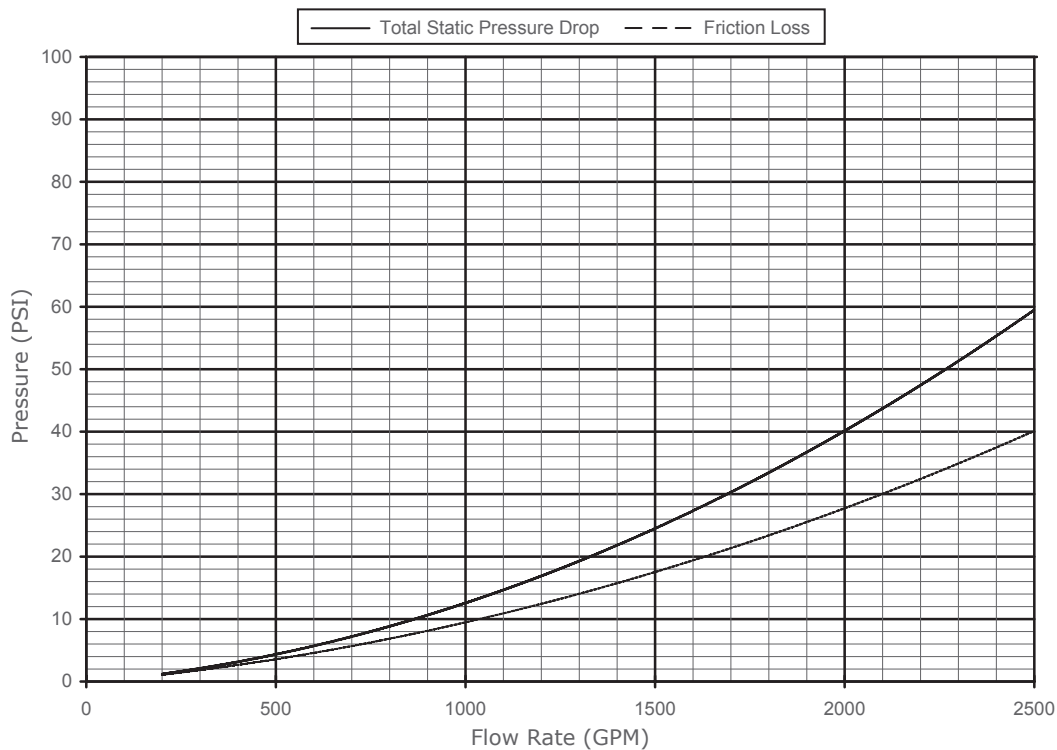

SM-1250E

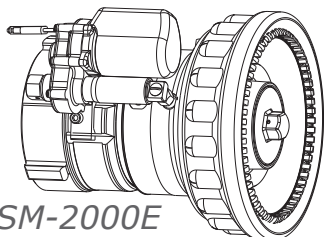

SM-2000E

X-Stream Series Master Stream Nozzles

The SM1250E and SM2000E are two electrically actuated master stream nozzles for use with the Scorpion EXM monitor. The X-Stream series nozzles automatically adjust to maintain an effective stream and maximum reach at variable or reduced flows. Electric actuators are completely sealed and allow precise pattern control from straight stream to wide fog.

SPECIFICATIONS			
Model	Inlet	Pressure PSI(BAR)	Flow Range - GPM(LPM)
SM1250E	3.5"	75 (5.17)	300-1250 (1136-4732)
SM2000E		80 (5.51)	500-2000 (1893-7571)